



classicexhibits

AERO™ Overhead Tension Fabric Structures

Aero™ Overhead Tension Fabric Structures are perfect for attracting attention and communicating your message at tradeshows, special events, or even as a point-of-purchase display.

Aero™ Overhead Tension Fabric Structures come in 23 standard 2D and 3D shapes, and each shape can be ordered in multiple sizes. Looking for something even more unusual? Custom shapes and sizes can be ordered to fit your unique marketing requirements.

3D Shapes



Round



Tapered Round



Oval



Triangle



Tapered Triangle



Three-Sided Curve



Pinwheel



Square



Tapered Square



Four-Sided Curve



Four-Sided Rectangle

2D Shapes



Disc



Rectangle



Curved Rectangle



Tapered Rectangle



Curved Tapered Rectangle



Flat Triangle



Curved Triangle



Ellipse



Lens



S-Curve

You came to be seen ... so be seen!



Aero™ Overhead Tension Fabric Structures are different, very different. Aero structures are economical to own, simple to assemble, and easy to maintain. No tools are required and packing is a breeze because every part has a specific place in the durable roto-molded case or corrugated carton. It's that simple. It's that easy. It's that affordable.

The key to exhibit success is to communicate a compelling message quickly and succinctly. Aero Structures do just that. The Aero System is designed to be beautiful, adaptable, and recognizable, whether it's for a 20 x 20 exhibit or an elegant special event. Choose from 23 stock structures—rounds, squares, pinwheels, rectangles, and triangles in 2D and 3D shapes—or design a custom shape that communicates your unique message.

FRAME

Let's begin by saying "no tools"—that's innovative and just plain smart engineering! Everything assembles with push-button connectors, and the instructions are straightforward and clear. The frame is made of lightweight 1.25" aluminum, precision milled using state of the art CNC equipment. With Aero, you won't need an engineering degree or tools to assemble your overhead tension fabric sign. Just an opposable thumb. Now that's smart.

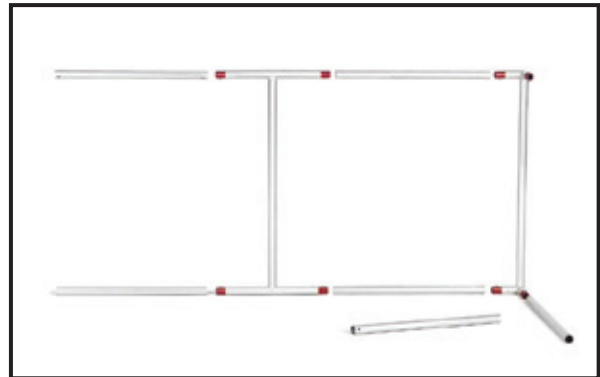

FABRIC FRAME COVERS

Only the highest quality fabric and zippers are used for Aero products. Every fabric frame cover is designed to last show after show, season after season. When it comes to graphics, "Image is everything." Our unmatched dye sublimation printing is guaranteed to make your images POP on the show floor with bright, clear colors and crisp graphics.



QUALITY CONSTRUCTION

All corners are precision welded and the tubes are CNC milled for parts that are durable and interchangeable.



You came to be seen ... so be seen!

CORNER AND JOINT CONNECTORS

We keep it simple: push-button connectors and pre-connected horizontal sections reduce assembly by two-thirds.



PACKAGING

Nobody does packaging like Classic Exhibits. Durable roto-molded cases with wheels or heavy corrugated cartons are standard (vs. the industry standard of lightweight one-way shipping containers). The packaging is jiggged to keep the contents organized for quick assembly and easy packing, and to prevent damage during shipping.



GRAPHICS

Classic Exhibits offers the Colossus dye sublimation processes. This process provides vivid colors, superior image detail, and photo quality with deep rich color saturation and fantastic image quality. For larger or volume applications, Colossus dye-sublimation is available up to 120" wide; it's great for large banners that still need brilliant, permanent color.



FABRIC OPTIONS

The standard fabric choice is polyknit. Polyknit holds color, is lightweight, is wrinkle resistant, and is flame retardant (with certificates available upon request). Other fabrics are available but may require additional lead-time and generally are more expensive. Fabric blocker is available for a nominal cost. Fabric samples are available upon request.



PILLOWCASE CONSTRUCTION

Our skilled sewing department takes extreme care when finishing the fabric hanging signs. Pillowcase construction allows for a snug, comfortable fit with an easy-to-use zipper for simple installation. Pillowcase construction guarantees a clean, finished look that molds to the metal support frame.

You came to be seen ... so be seen!



ROUND

The Aero™ Overhead Round is always a trade show and special event favorite. As the most noticeable of all shapes, it offers unparalleled 360° visibility for your logo or key message.

The Round comes in multiple diameters - from 10 ft. to 12 ft - and can be ordered as a Tapered Round as well. Custom sizes are also available.

For even more visibility, the optional bottom fabric cover adds an additional surface in the high impact but often under-utilized space above your exhibit. For a stunning look, add rotation and your sign will take center stage!

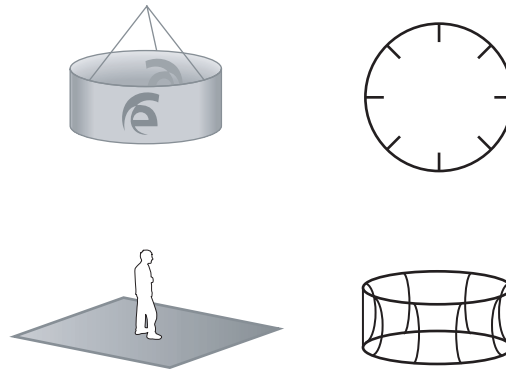

SIMILAR SHAPES



Tapered Round (3D)



Three-Sided Curve (3D)

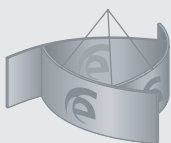

Pinwheel (3D)

SPECIFICATIONS

Sizes
(length of each side)

- 10' x 36"
- 10' x 42"
- 12' x 42"
- 12' x 60"

Larger, Smaller,
& Custom Sizes
Available

Additional Fabric Options

Opaque liner—hides image bleed on second side (recommended)

Bottom covered with white fabric

Bottom open

Fabric Options

- Image on one side
- Image on both sides

Options

Motor for rotation

Set-up

No tools assembly:
push button connecting hardware

Detailed set-up instructions included

Show hall or event rigging labor may be required

Packaging

Heavy corrugated cartons (standard)

11" x 4' x 24" roto-molded case with handle and wheels (additional cost)

How to Order

Choose the size, fabric option, and mounting options

Turnaround

Please allow 10-15 business days for production and graphics of standard shapes (rush orders available depending on current production)



TAPERED ROUND

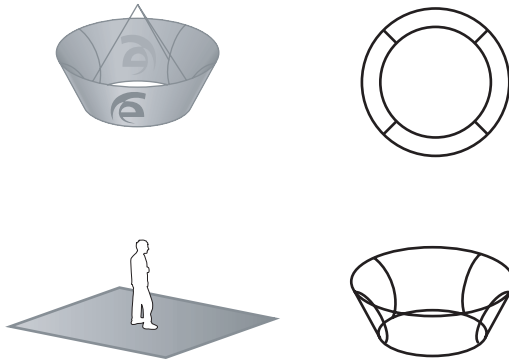

TAPERED ROUND

The Aero™ Overhead Tapered Round combines the high impact of the 3D Round with an angled surface for ideal visibility at any location on the floor.

The Tapered Round comes in multiple diameters—from 10 ft. to 12 ft.—and can be ordered as a Round as well. Custom sizes are also available.

For this most noticeable of all shapes, consider adding a bottom fabric cover and rotation for a more dramatic flair.

SPECIFICATIONS

SIMILAR SHAPES

Sizes (length of each side)

- 10' x 36"
- 10' x 42"
- 12' x 42"
- 12' x 60"

Larger, Smaller,
& Custom Sizes
Available

Additional Fabric Options

Opaque liner—hides image bleed on second side (recommended)

Bottom covered with white fabric

Bottom open

Fabric Options

Image on one side
Image on both sides

Options

Motor for rotation

Set-up

No tools assembly:
push button connecting hardware

Detailed set-up instructions included

Show hall or event rigging labor may be required

Packaging

11" x 4' x 24" roto-molded case with handle and wheels (additional cost)

How to Order

Choose the size, fabric option, and mounting options

Turnaround

Please allow 10-15 business days for production and graphics of standard shapes (rush orders available depending on current production)

FILE PREPARATION GUIDELINES pages 27-30

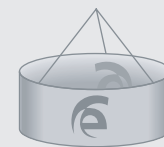

Round (3D)



Three-Sided Curve (3D)

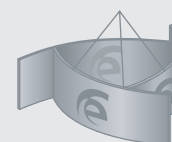

Pinwheel (3D)





OVAL

A perennial favorite at trade shows, the Aero™ Overhead Oval offers a large two-sided graphic that looks stunning from any angle and is a great value.

For larger booths, the oval can be combined with overhead two-dimensional signs for an extraordinary multi-dimensional look.

The Oval comes in multiple curves—from 10 ft. to 12 ft. It ships in a heavy corrugated or reusable portable case(s), assembles in minutes without tools, and comes with Classic Exhibits' legendary set-up instructions. Custom sizes are also available.

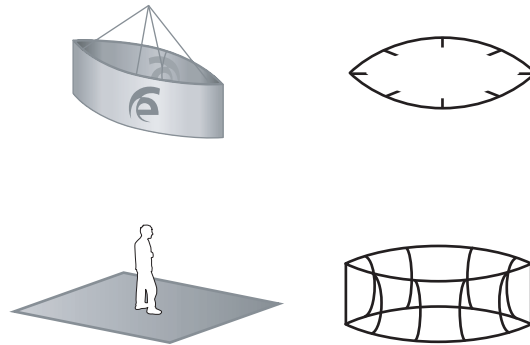

SIMILAR SHAPES

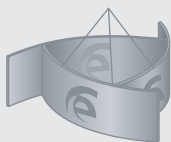

Pinwheel (3D)

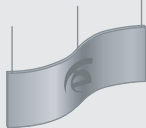

S-Curve (2D)



Ellipse (2D)

SPECIFICATIONS

Sizes
(length of each side)

- 10' x 36"
- 10' x 42"
- 12' x 42"
- 12' x 60"

Larger, Smaller,
& Custom Sizes
Available

Additional Fabric Options

Opaque liner—hides image bleed on second side (recommended)

Bottom covered with white fabric

Bottom open

Fabric Options

- Image on one side
- Image on both sides

Options

Motor for rotation

Set-up

No tools assembly:
push button connecting hardware

Detailed set-up instructions included

Show hall or event rigging labor may be required

Packaging

Heavy corrugated cartons (standard)

11" x 4' x 24" roto-molded case with handle and wheels (additional cost)

How to Order

Choose the size, fabric option, and mounting options

Turnaround

Please allow 10-15 business days for production and graphics of standard shapes (rush orders available depending on current production)



TRIANGLE



TRIANGLE

Who doesn't like a triangle? Three equal sides, perfect symmetry, and visually balanced. It makes everyone yearn for 10th grade geometry class.

The Aero™ Overhead Triangle offers an eye-catching and appealing shape that enhances the overall marketing message with a simple but dramatic effect.

It can be ordered in multiple sizes—from 8 ft. to 16 ft. Custom sizes are also available. Consider a bottom fabric cover for a tailored look and another surface for graphics. Rotation is also available.

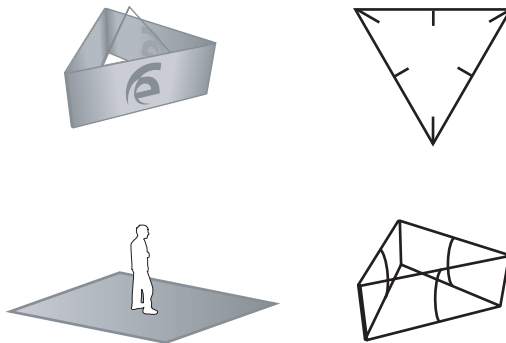

SPECIFICATIONS

SIMILAR SHAPES

<p>Sizes (length of each side)</p> <p>10' x 36" 10' x 42" 12' x 42" 12' x 60" Larger, Smaller, & Custom Sizes Available</p> <p>Additional Fabric Options Opaque liner—hides image bleed on second side (recommended)</p> <p>Bottom covered with white fabric</p> <p>Bottom open</p>	<p>Fabric Options Image on one side Image on both sides</p> <p>Options Motor for rotation</p> <p>Set-up No tools assembly: push button connecting hardware</p> <p>Detailed set-up instructions included</p> <p>Show hall or event rigging labor may be required</p>	<p>Packaging Heavy corrugated cartons (standard)</p> <p>11" x 4' x 24" roto-molded case with handle and wheels (additional cost)</p> <p>How to Order Choose the size, fabric option, and mounting options</p> <p>Turnaround Please allow 10-15 busi- ness days for production and graphics of standard shapes (rush orders avail- able depending on current production)</p>
---	--	--

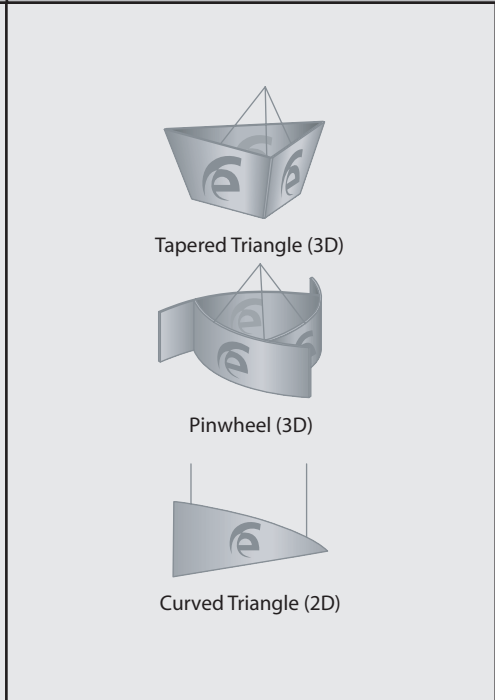



TAPERED TRIANGLE

If you like the triangle shape but are looking for something with a little more pizzazz, the Aero™ Overhead Tapered Triangle makes a subtle, classy, and powerful statement that demands to be seen.

The Tapered Triangle packs in a heavy corrugated or reusable portable case(s) for convenient shipping and storage.

Multiple sizes are available—from a recognizable 8 ft. to a “can’t miss” 12 ft. It comes in a straight wall shape as well. Rotation is also available.

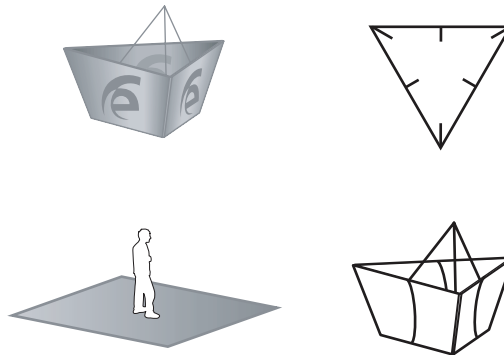

SIMILAR SHAPES



Triangle (3D)



Pinwheel (3D)



Three-Sided Curve (3D)

SPECIFICATIONS

Sizes
(length of each side)

- 10' x 36"
- 10' x 42"
- 12' x 42"
- 12' x 60"

Larger, Smaller,
& Custom Sizes
Available

Additional Fabric Options

Opaque liner—hides image bleed on second side (recommended)

Bottom covered with white fabric

Bottom open

Fabric Options

Image on one side
Image on both sides

Options

Motor for rotation

Set-up

No tools assembly:
push button connecting hardware

Detailed set-up instructions included

Show hall or event rigging labor may be required

Packaging

Heavy corrugated cartons (standard)

11" x 4' x 24" roto-molded case with handle and wheels (additional cost)

How to Order

Choose the size, fabric option, and mounting options

Turnaround

Please allow 10-15 business days for production and graphics of standard shapes (rush orders available depending on current production)



THREE-SIDED CURVE

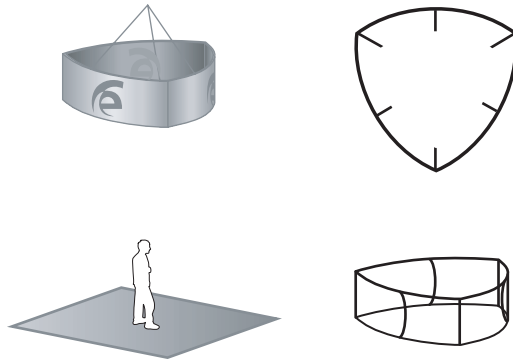

THREE-SIDED CURVE

Take away those sharp edges with the Aero™ Overhead Three-Sided Curve. This shape is a triangle with some serious circle envy.

You get the benefits of both a circle and a triangle: maximum visibility, visual balance, and captivating "eye candy." Plus, it comes in as many sizes as its circle and triangle cousins.

Custom sizes are available. For a little more "eye candy" add rotation and lighting.

SPECIFICATIONS

SIMILAR SHAPES

<p>Sizes (length of each side)</p> <p>10' x 36" 10' x 48" 12' x 48" Larger, Smaller, & Custom Sizes Available</p> <p>Additional Fabric Options Opaque liner—hides image bleed on second side (recommended)</p> <p>Bottom covered with white fabric</p> <p>Bottom open</p>	<p>Fabric Options Image on one side Image on both sides</p> <p>Options Motor for rotation</p> <p>Set-up No tools assembly: push button connecting hardware</p> <p>Detailed set-up instructions included</p> <p>Show hall or event rigging labor may be required</p>	<p>Packaging Heavy corrugated cartons (standard)</p> <p>11" x 4' x 24" roto-molded case with handle and wheels (additional cost)</p> <p>How to Order Choose the size, fabric option, and mounting options</p> <p>Turnaround Please allow 10-15 busi- ness days for production and graphics of standard shapes (rush orders avail- able depending on current production)</p>
---	--	--

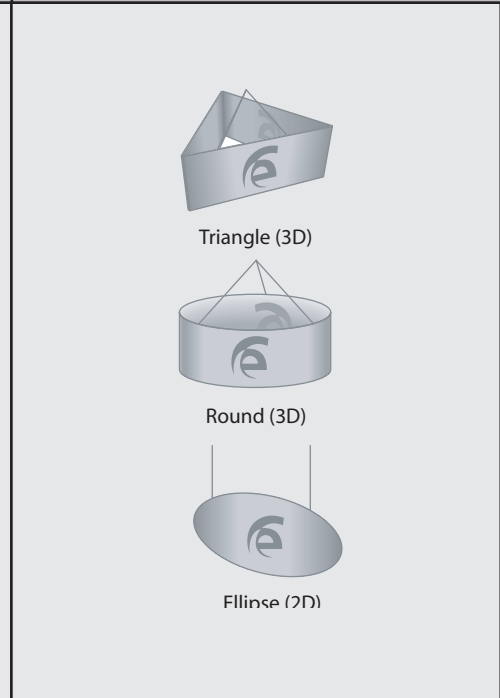



PINWHEEL

Move away from the ordinary with the Aero™ Overhead Pinwheel. Its curious curves, intriguing connection points, and flowing movement will draw everyone's gaze upwards.

It's easy to assemble and packs into a heavy corrugated or reusable portable case(s) for convenient shipping. Choose from 10 ft. to 12 ft. sides. Custom sizes are also available.

For a more dazzling effect, consider adding rotation to this unmistakable shape.

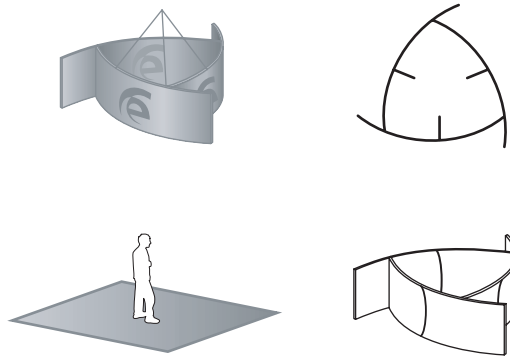

SIMILAR SHAPES

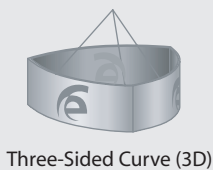

Three-Sided Curve (3D)

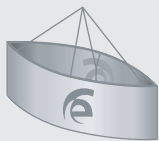

Oval (3D)

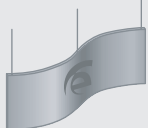

S-Curve (2D)

SPECIFICATIONS

Sizes
(length of each side)

- 10' x 36"
- 10' x 48"
- 12' x 48"
- 12' x 60"

Larger, Smaller,
& Custom Sizes
Available

Additional Fabric Options

Opaque liner—hides image
bleed on second side
(recommended)

Bottom covered with
white fabric

Bottom open

Fabric Options

- Image on one side
- Image on both sides

Options

Motor for rotation

Set-up

No tools assembly:
push button connecting
hardware

Detailed set-up
instructions included

Show hall or event
rigging labor may be
required

Packaging

Heavy corrugated cartons
(standard)

11" x 4' x 24" roto-molded
case with handle and
wheels (additional cost)

How to Order

Choose the size, fabric
option, and mounting
options

Turnaround

Please allow 10-15 busi-
ness days for production
and graphics of standard
shapes (rush orders avail-
able depending on current
production)



SQUARE



SQUARE

For getting attention on the show floor, there's nothing "square" about the Aero™ Overhead Square! Each side is the ideal visual billboard to reach every corner of an event with your unique branding.

Comes in a Tapered Square shape too! Custom sizes are also available.

For even more visibility, the optional bottom fabric cover adds an additional surface in the high impact but often under-utilized space above your exhibit. For a stunning "can't miss" look, add rotation.

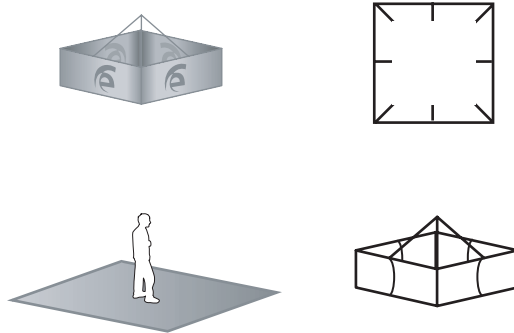

SPECIFICATIONS

SIMILAR SHAPES

Sizes (length of each side)

- 10' x 36"
- 10' x 42"
- 12' x 42"
- 12' x 60"

Larger, Smaller,
& Custom Sizes
Available

Additional Fabric Options

Opaque liner—hides image bleed on second side (recommended)

Bottom covered with white fabric

Bottom open

Fabric Options

Image on one side
Image on both sides

Options

Motor for rotation

Set-up

No tools assembly:
push button connecting hardware

Detailed set-up
instructions included

Show hall or event
rigging labor may be
required

Packaging

Heavy corrugated cartons
(standard)

11" x 4' x 24" roto-molded
case with handle and
wheels (additional cost)

How to Order

Choose the size, fabric
option, and mounting
options

Turnaround

Please allow 10-15 busi-
ness days for production
and graphics of standard
shapes (rush orders avail-
able depending on current
production)



Tapered Square (3D)

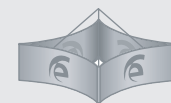

Four-Sided Curve (3D)

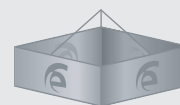

Four-Sided Rectangle (3D)





TAPERED SQUARE

TAPERED SQUARE

Coming at you from four sides, the Aero™ Overhead Tapered Square always gets noticed. The Tapered Square, like its fraternal twin the Square, is a popular choice for trade shows, special events, and retail settings.

It comes in multiple sizes—from 10 ft. per side to 12 ft. per side. Custom sizes are also available.

For visibility at any angle, the Tapered Square can be used as a single sign, or in larger booth spaces, can be paired with multiple tapered squares to emphasize specific products or marketing messages.

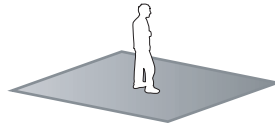
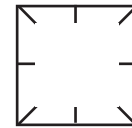

SIMILAR SHAPES



Square (3D)



Tapered Triangle (3D)



Tapered Round (3D)

SPECIFICATIONS

Sizes (length of each side)

10' x 36"
10' x 42"
12' x 42"
12' x 60"

Larger, Smaller,
& Custom Sizes
Available

Additional Fabric Options

Opaque liner—hides image bleed on second side (recommended)

Bottom covered with white fabric

Bottom open

Fabric Options

Image on one side
Image on both sides

Options

Motor for rotation

Set-up

No tools assembly:
push button connecting hardware

Detailed set-up instructions included

Show hall or event rigging labor may be required

Packaging

Heavy corrugated cartons (standard)

11" x 4' x 24" roto-molded case with handle and wheels (additional cost)

How to Order

Choose the size, fabric option, and mounting options

Turnaround

Please allow 10-15 business days for production and graphics of standard shapes (rush orders available depending on current production)



FOUR-SIDED CURVE

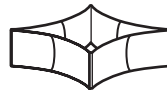
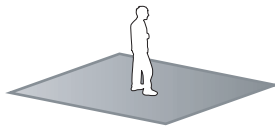

FOUR-SIDED CURVE

When the square just isn't enough, get fancy and draw more attention to your booth or special event with the Aero™ Overhead Four-Sided Curve. This shape complements any exhibit with a bold presence.

The Four-Sided Curve comes in multiple sizes—from 10 ft. to 12 ft. Custom sizes are also available.

When you need to reach into all four corners of the show hall, consider the Four-Sided Curve. It screams to be seen.

SPECIFICATIONS

SIMILAR SHAPES

Sizes (length of each side)

10' x 36"
10' x 48"
12' x 48"
12' x 60"

Larger, Smaller,
& Custom Sizes
Available

Additional Fabric Options

Opaque liner—hides image bleed on second side (recommended)

Bottom covered with white fabric

Bottom open

Fabric Options

Image on one side
Image on both sides

Options

Motor for rotation

Set-up

No tools assembly:
push button connecting hardware

Detailed set-up
instructions included

Show hall or event
rigging labor may be
required

Packaging

Heavy corrugated cartons
(standard)

11" x 4' x 24" roto-molded
case with handle and
wheels (additional cost)

How to Order

Choose the size, fabric
option, and mounting
options

Turnaround

Please allow 10-15 busi-
ness days for production
and graphics of standard
shapes (rush orders avail-
able depending on current
production)



Four-Sided Rectangle (3D)



Three-Sided Curve (3D)



Lens (2D)





FOUR-SIDED RECTANGLE

FOUR-SIDED RECTANGLE

The Aero™ Overhead Four-Sided Rectangle can stretch your message, whether it's the same message on each side or something different. The rectangle shape is excellent for larger island spaces where a big presence is needed because the two longer sides measure from a brash 10 ft. to a bold 12 ft. Custom sizes are also available.

When you need to reach into all four corners of the show hall, the Four-Sided Rectangle makes an unmistakable statement.

It ships in a heavy corrugated or reusable portable case(s), assembles in minutes without tools, and comes with Classic Exhibits' legendary set-up instructions.

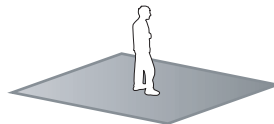
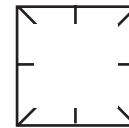
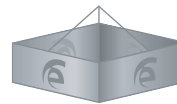

SIMILAR SHAPES



Square (3D)



Four-Sided Curve (3D)



Tapered Rectangle (2D)

SPECIFICATIONS

Sizes (length of each side)

10' x 5' x 42"

12' x 6' x 42"

12' x 6' x 60"

Larger, Smaller,
& Custom Sizes
Available

Additional Fabric Options

Opaque liner—hides image
bleed on second side
(recommended)

Bottom covered with
white fabric

Bottom open

Fabric Options

Image on one side

Image on both sides

Options

Motor for rotation

Set-up

No tools assembly:
push button connecting
hardware

Detailed set-up
instructions included

Show hall or event
rigging labor may be
required

Packaging

Heavy corrugated cartons
(standard)

11" x 4" x 24" roto-molded
case with handle and
wheels (additional cost)

How to Order

Choose the size, fabric
option, and mounting
options

Turnaround

Please allow 10-15 busi-
ness days for production
and graphics of standard
shapes (rush orders avail-
able depending on current
production)





DISC

The Aero™ Overhead Disc is a simple but very effective sign when used creatively. Consider matching the Disc with other Aero shapes, either vertically or horizontally, to create a spectacular ceiling or overhead mobile.

Choose from a petite 3 ft. disc to an impressive 12 ft. ceiling disc. Custom sizes are also available.

The frame assembles in no time with quick-connect buttons. Best of all, no tools are necessary.

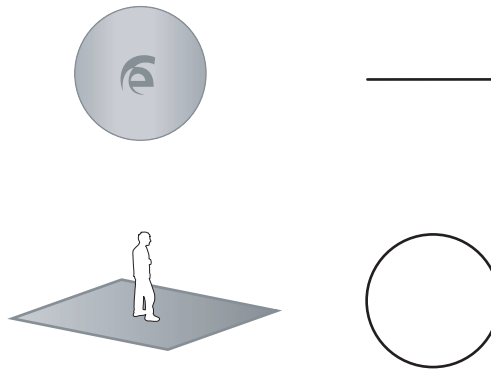

SIMILAR SHAPES



Rectangle (2D)

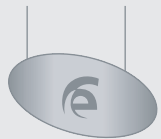

Ellipse (2D)



Tapered Round (3D)

SPECIFICATIONS

Sizes
(length of each side)

- 3'
- 4'
- 5'
- 6'
- 8'
- 10'
- 12'

Larger, Smaller,
& Custom Sizes
Available

Additional Fabric Options

Opaque liner—hides image bleed on second side (recommended)

Fabric Options

Image on one side
Image on both sides

Set-up

No tools assembly:
push button connecting hardware

Detailed set-up instructions included

Show hall or event rigging labor may be required

Packaging

Heavy corrugated cartons (standard)

11" x 4' x 24" roto-molded case with handle and wheels (additional cost)

How to Order

Choose the size, fabric option, and mounting options

Turnaround

Please allow 10-15 business days for production and graphics of standard shapes (rush orders available depending on current production)



RECTANGLE

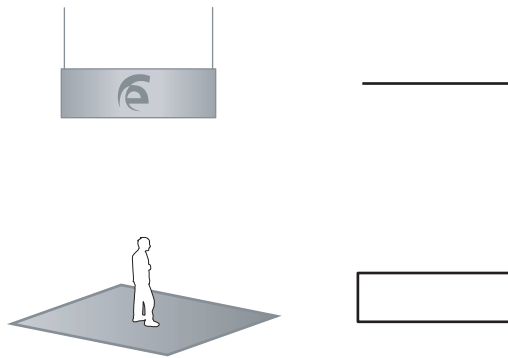

RECTANGLE

Often the simplest shapes have the most creative uses. The Aero™ Overhead Rectangle can be designed as an overhead banner, a floating ceiling, or an enclosure. For perimeter exhibits, the Rectangle increases the visibility of 10' and 20' inline booths.

In larger exhibits and special events, the Rectangle can make the difference between being seen and just being there.

Select from eleven sizes, ranging from 6' x 36" to 12' x 60". Images can be printed on both sides.

SPECIFICATIONS

Sizes
(length of each side)

- 6' x 36"
- 8' x 36"
- 8' x 48"
- 10' x 36"
- 10' x 48"
- 10' x 60"
- 12' x 36"
- 12' x 48"
- 12' x 60"

Larger, Smaller,
& Custom Sizes
Available

Additional Fabric Options
Opaque liner—hides image
bleed on second side
(recommended)

Fabric Options

Image on one side
Image on both sides

Set-up

No tools assembly:
push button connecting
hardware

Detailed set-up
instructions included

Show hall or event
rigging labor may be
required

Packaging

Heavy corrugated cartons
(standard)

11" x 4' x 24" roto-molded
case with handle and
wheels (additional cost)

How to Order

Choose the size, fabric
option, and mounting
options

Turnaround

Please allow 10-15 busi-
ness days for production
and graphics of standard
shapes (rush orders avail-
able depending on current
production)

SIMILAR SHAPES



Curved Rectangle (2D)

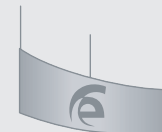

Curved Tapered Rectangle (2D)



Four-Sided Rectangle (3D)





CURVED RECTANGLE

Perfect for a wraparound look to highlight a product. The Aero™ Overhead Curved Rectangle works great as a header or a ceiling.

When combined with other 2D curved signs, the Aero Curved Rectangle is an excellent multi-layered overhead sign in larger exhibits or at special events.

A rotation option is available. Comes in eleven sizes. Custom sizes are also available.

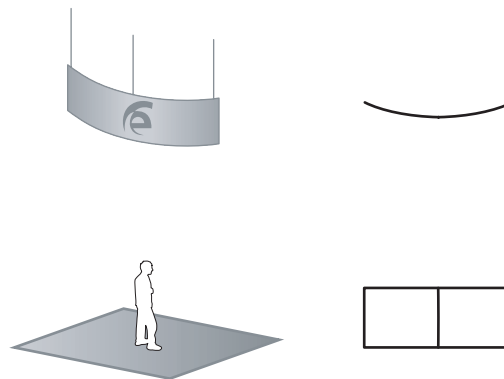

SIMILAR SHAPES

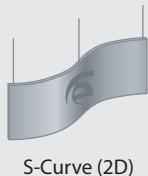
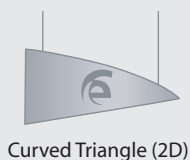
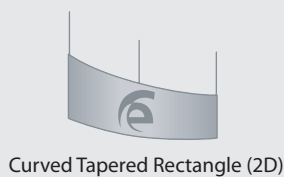

SPECIFICATIONS

Sizes
(length of each side)

- 6' x 36"
- 8' x 36"
- 8' x 48"
- 10' x 36"
- 10' x 48"
- 10' x 60"
- 12' x 36"
- 12' x 48"
- 12' x 60"

Larger, Smaller,
& Custom Sizes
Available

Additional Fabric Options
Opaque liner—hides image bleed on second side (recommended)

Fabric Options

Image on one side
Image on both sides

Set-up

No tools assembly:
push button connecting hardware

Detailed set-up instructions included

Show hall or event rigging labor may be required

Packaging

Heavy corrugated cartons (standard)

11" x 4' x 24" roto-molded case with handle and wheels (additional cost)

How to Order

Choose the size, fabric option, and mounting options

Turnaround

Please allow 10-15 business days for production and graphics of standard shapes (rush orders available depending on current production)



TAPERED RECTANGLE

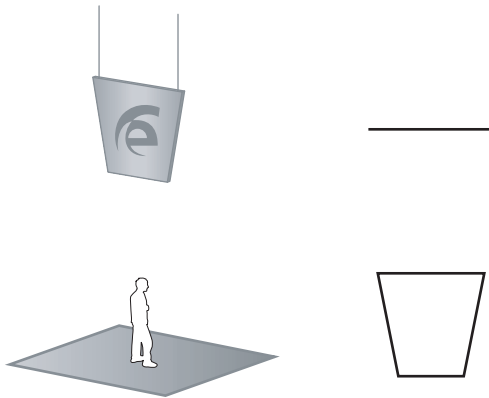

TAPERED RECTANGLE

When you really need to zero in on something, the Aero™ Overhead Tapered Rectangle points people in the right direction. Up, down, or sideways, it doesn't matter because this versatile sign emphasizes your message.

Use this distinctive curved trapezoid shape as a ceiling, banner, or wall.

A rotation option is available. Comes in eleven sizes. Custom sizes are also available.

SPECIFICATIONS

Sizes (length of each side)

6' x 36" x 24"
 8' x 36" x 24"
 8' x 48" x 36"
 10' x 36" x 24"
 10' x 48" x 36"
 10' x 60" x 48"
 12' x 36" x 24"
 12' x 48" x 36"
 12' x 60" x 48"

Additional Fabric Options
 Opaque liner—hides image bleed on second side (recommended)

Fabric Options

Image on one side
 Image on both sides

Set-up

No tools assembly:
 push button connecting hardware

Detailed set-up instructions included

Show hall or event rigging labor may be required

Packaging

Heavy corrugated cartons (standard)

11" x 4' x 24" roto-molded case with handle and wheels (additional cost)

How to Order

Choose the size, fabric option, and mounting options

Turnaround

Please allow 10-15 business days for production and graphics of standard shapes (rush orders available depending on current production)

SIMILAR SHAPES



Curved Tapered Rectangle (2D)

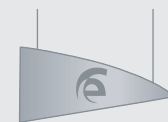

Curved Triangle (2D)



Four-Sided Rectangle (3D)





CURVED TAPERED RECTANGLE

CURVED TAPERED RECTANGLE

It's curved. It's a rectangle. It's tapered. When you want a look that's as unique as your exhibit or special event, the Aero™ Overhead Curved Tapered Rectangle is a great choice. The shape is unmistakable and demands to be seen and admired.

The Curved Tapered Rectangle ships in a heavy corrugated or reusable portable case(s), assembles in minutes without tools, and comes with Classic Exhibits' legendary set-up instructions. Standard and custom sizes are available.

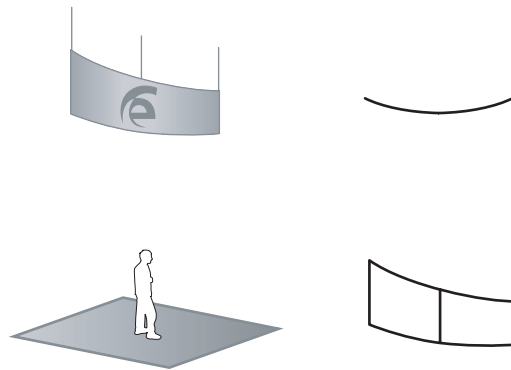

SIMILAR SHAPES

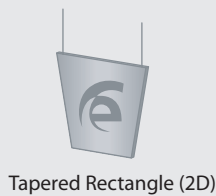

SPECIFICATIONS

Sizes (length of each side)

6' x 36" x 24"
 8' x 36" x 24"
 8' x 48" x 36"
 10' x 36" x 24"
 10' x 48" x 36"
 10' x 60" x 48"
 12' x 36" x 24"
 12' x 48" x 36"
 12' x 60" x 48"

Larger, Smaller,
 & Custom Sizes
 Available

Additional Fabric Options

Opaque liner—hides image bleed on second side (recommended)

Fabric Options

Image on one side
 Image on both sides

Set-up

No tools assembly:
 push button connecting hardware

Detailed set-up
 instructions included

Show hall or event
 rigging labor may be
 required

Packaging

Heavy corrugated cartons
 (standard)

11" x 4' x 24" roto-molded
 case with handle and
 wheels (additional cost)

How to Order

Choose the size, fabric
 option, and mounting
 options

Turnaround

Please allow 10-15 busi-
 ness days for production
 and graphics of standard
 shapes (rush orders avail-
 able depending on current
 production)



FLAT TRIANGLE

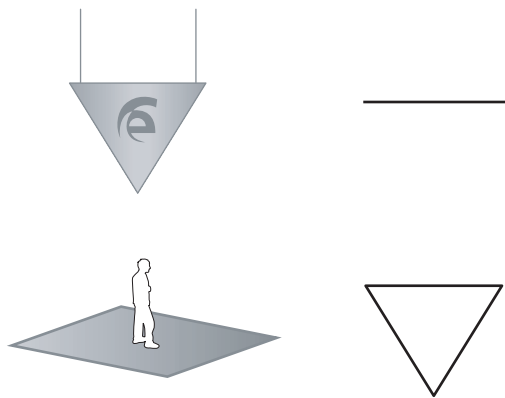

FLAT TRIANGLE

The Aero™ Overhead Flat Triangle is an equilateral triangle (three equal sides) that always points people in the right direction—to you!

Great for calling out special products in your booth or calling attention to something important! Because it's small, you can use several to focus on your key messages.

Lightweight and portable, it's a smart economical choice for smaller or larger displays. Also available as a Curved Triangle.

SPECIFICATIONS

SIMILAR SHAPES

<p>Sizes (length of each side)</p> <p>3' 4' 5' 6' 8' 10' 12' Larger, Smaller, & Custom Sizes Available</p> <p>Additional Fabric Options Opaque liner—hides image bleed on second side (recommended)</p>	<p>Fabric Options Image on one side Image on both sides</p> <p>Set-up No tools assembly: push button connecting hardware</p> <p>Detailed set-up instructions included</p> <p>Show hall or event rigging labor may be required</p>	<p>Packaging Heavy corrugated cartons (standard)</p> <p>11" x 4' x 24" roto-molded case with handle and wheels (additional cost)</p> <p>How to Order Choose the size, fabric option, and mounting options</p> <p>Turnaround Please allow 10-15 busi- ness days for production and graphics of standard shapes (rush orders avail- able depending on current production)</p>
---	---	--

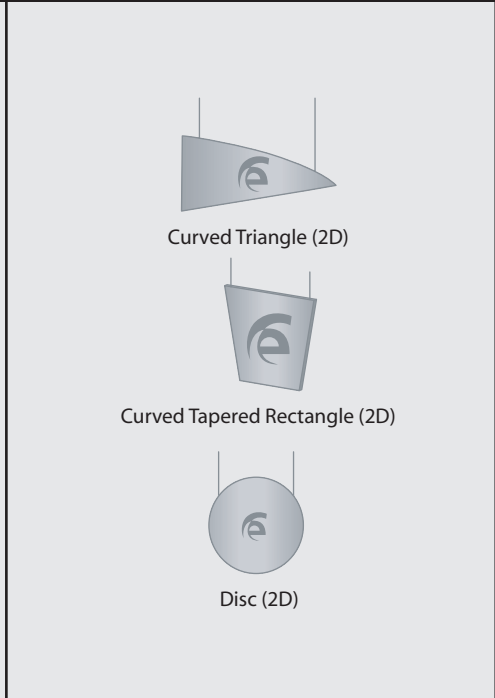



CURVED TRIANGLE

The Aero™ Overhead Curved Triangle looks like a banner but works like a beacon. This isosceles triangle can be hung flat, lengthwise, or downward.

Larger sizes make for an attractive floating ceiling in the often under-utilized space above an exhibit.

The Curved Triangle ships in a heavy corrugated or reusable portable case(s), assembles in minutes without tools, and comes with Classic Exhibits' legendary set-up instructions. Standard and custom sizes are available.

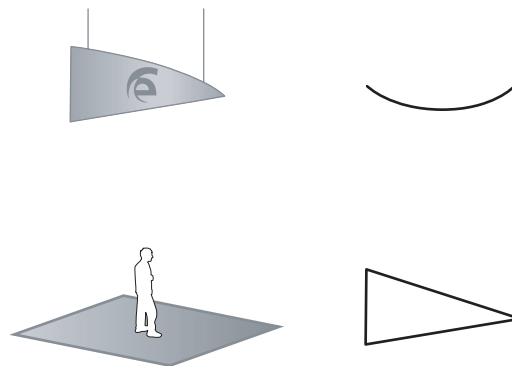

SIMILAR SHAPES

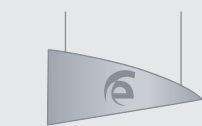

Curved Triangle (2D)



Ellipse (2D)

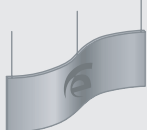

S-Curve (2D)

SPECIFICATIONS

Sizes
(length of each side)

- 6' x 36"
- 8' x 36"
- 8' x 48"
- 10' x 36"
- 10' x 48"
- 10' x 60"
- 12' x 36"
- 12' x 48"
- 12' x 60"

Larger, Smaller,
& Custom Sizes
Available

Additional Fabric Options

Opaque liner—hides image bleed on second side (recommended)

Fabric Options

Image on one side
Image on both sides

Set-up

No tools assembly:
push button connecting hardware

Detailed set-up instructions included

Show hall or event rigging labor may be required

Packaging

Heavy corrugated cartons (standard)

11" x 4' x 24" roto-molded case with handle and wheels (additional cost)

How to Order

Choose the size, fabric option, and mounting options

Turnaround

Please allow 10-15 business days for production and graphics of standard shapes (rush orders available depending on current production)



ELLIPSE

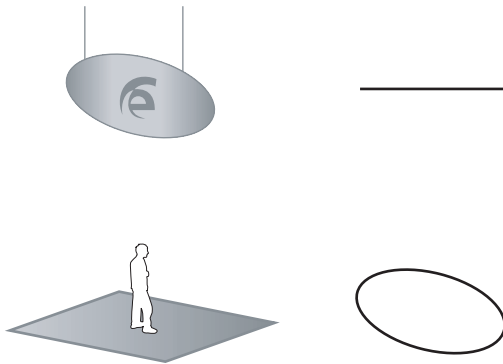

ELLIPSE

Be creative with a shape that's too cool to be just a circle. The Aero™ Overhead Ellipse is a great two-sided display when mounted overhead or as part of an exhibit.

Want something a little different? Go for the Curved Ellipse.

Select from five sizes ranging from a subtle 6 ft. ellipse to a soaring 12 ft. sign. Custom sizes are also available.

SPECIFICATIONS

SIMILAR SHAPES

Sizes
(length of each side)

- 6' x 36"
- 8' x 36"
- 10' x 48"
- 12' x 48"

Larger, Smaller,
& Custom Sizes
Available

Additional Fabric Options

Opaque liner—hides image bleed on second side (recommended)

Fabric Options

Image on one side
Image on both sides

Set-up

No tools assembly:
push button connecting hardware

Detailed set-up instructions included

Show hall or event rigging labor may be required

Packaging

Heavy corrugated cartons (standard)

11" x 4' x 24" roto-molded case with handle and wheels (additional cost)

How to Order

Choose the size, fabric option, and mounting options

Turnaround

Please allow 10-15 business days for production and graphics of standard shapes (rush orders available depending on current production)



Disc (2D)



Oval (3D)



Three-Sided Curve (3D)





LENS

Perfect for highlighting a single product or a workstation, the Aero™ Overhead Lens ensures that you will be seen and remembered.

For visibility at any angle, the Lens can be used as a single sign, or in larger booth spaces, can be paired with multiple Lens signs to emphasize specific products or marketing messages.

Lightweight and portable, it's a smart economical choice for smaller or larger displays. Also available as a Curved Lens.

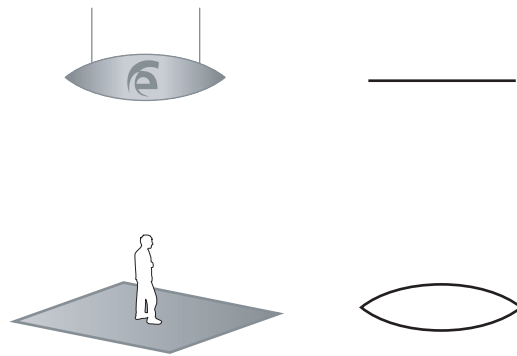

SIMILAR SHAPES

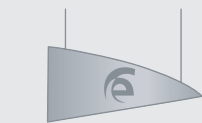

Curved Triangle (2D)

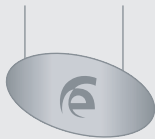

Ellipse (2D)

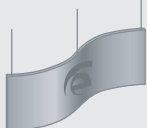

S-Curve (2D)

SPECIFICATIONS

Sizes
(length of each side)

- 6' x 36"
- 8' x 36"
- 8' x 48"
- 10' x 36"
- 10' x 48"
- 10' x 60"
- 12' x 36"
- 12' x 48"
- 12' x 60"

Larger, Smaller,
& Custom Sizes
Available

Additional Fabric Options

Opaque liner—hides image bleed on second side (recommended)

Fabric Options

- Image on one side
- Image on both sides

Set-up

No tools assembly:
push button connecting hardware

Detailed set-up instructions included

Show hall or event rigging labor may be required

Packaging

Heavy corrugated cartons (standard)

11" x 4' x 24" roto-molded case with handle and wheels (additional cost)

How to Order

Choose the size, fabric option, and mounting options

Turnaround

Please allow 10-15 business days for production and graphics of standard shapes (rush orders available depending on current production)



S-CURVE

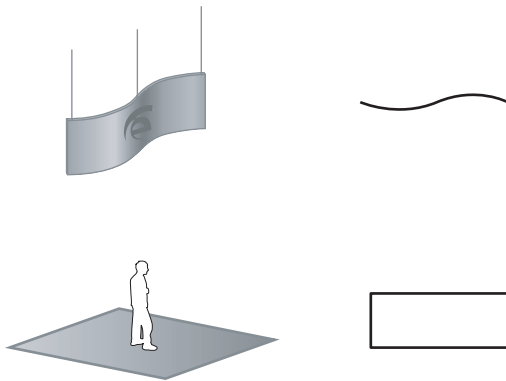

S-CURVE

The Aero™ Overhead S-Curve is a shape to be admired. Hang it as a long banner, as a wavy vertical sign, or as a creative canopy. Even as a wall.

Be creative. Highlight an image or word on the left and reverse the same image on the right.

For a more dazzling effect, consider adding rotation to this unique shape. Multiple sizes are available. Ships in heavy corrugated or reusable portable case(s).

SPECIFICATIONS

SIMILAR SHAPES

<p>Sizes (length of each side)</p> <p>6" x 36" 8" x 36" 8" x 60" 10' x 48" 10' x 120" 12' x 48" 12' x 84" 12' x 144" Larger, Smaller, & Custom Sizes Available</p> <p>Additional Fabric Options Opaque liner—hides image bleed on second side (recommended)</p>	<p>Fabric Options Image on one side Image on both sides</p> <p>Set-up No tools assembly: push button connecting hardware</p> <p>Detailed set-up instructions included</p> <p>Show hall or event rigging labor may be required</p>	<p>Packaging Heavy corrugated cartons (standard)</p> <p>11" x 4' x 24" roto-molded case with handle and wheels (additional cost)</p> <p>How to Order Choose the size, fabric option, and mounting options</p> <p>Turnaround Please allow 10-15 busi- ness days for production and graphics of standard shapes (rush orders avail- able depending on current production)</p>
---	---	--

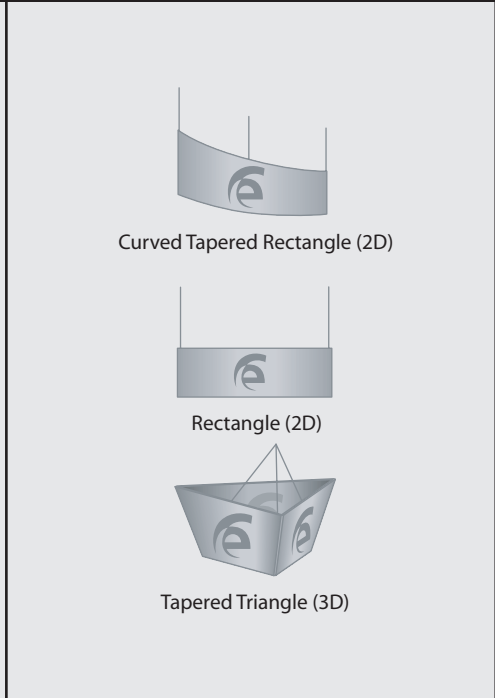

FABRIC FILE PREPARATION GUIDELINES

Prepared by Optima Graphics

866.652.2100

The following guidelines are designed to help you set up your file for digital graphics so that there will be as few delays and problems as possible in the production of your job. All graphic files will first be received by Classic Exhibits and then will be forwarded to the Optima Graphics Department with the order for all hardware.

How Should My File Be Laid Out?

All files should be set up:

- To scale
- With cropmarks indicated
- Text should be converted to curves or outlines. Quark does offer text to box, but it is time consuming and often corrupts once the file is reopened.
- INPUT resolution on bitmap files is 72 ppi at final size and 100 ppi if your bitmap file contains text.

What Formats And Programs Can I Use?

Files may be MAC or PC formatted. The files can be set up in any of the following programs:

- Adobe PhotoShop CS2
- Macromedia Freehand MX
- Adobe Illustrator CS2
- Quark Xpress 6.0
- In Design CS2

Below files must be exported or saved as an .EPS:

- PageMaker 7.0

NOTE: If Pagemaker files are sent, we must export the files as an .EPS. This does not always export correctly and may incur additional art time to export or for the files to work properly.

How Should I Send My Artwork?

Artwork can be sent on the following types of media via:

- FTP site
- E-mail
- CD-ROM
- DVD Ram
- DVD Rom
- DDS DAT Tape (Retrospect formatted, MAC only, 4MM wide, 90M long. Please put all of the files that the Graphics Department will be using to produce your job in one main folder. Also send along both the catalog file and a list of the files that are being used).

What Else Is Important To Consider When Setting Up Files?

PhotoShop files should be saved as a TIFF , EPS, or PhotoShop

file. If there are "placed images" in Illustrator, Freehand, or QuarkXPress, be sure to send the support files so that the quality of the images can be checked. This is especially important for photographic or highly detailed images. DO NOT send Freehand or Quark EPS files unless you send the support files. Production cannot manipulate the content, proportion or color of these eps files. Illustrator EPS files are usable but result in files that are larger than necessary.

What Do I Do About Fonts?

To avoid any problems with fonts, always include all fonts. PC and MAC fonts are not compatible. Therefore, when working in a PC format, the Graphics Department requests that you convert all fonts to outlines or curves. If you are PC based and working in a program that does not allow you to convert the fonts to outlines, the Graphics Department may end up having to substitute fonts. Supplying MAC fonts is strongly recommended. Due to slight variations in fonts (kerning, baseline, etc) substituting fonts may change the layout.

What Else Do I Need To Send?

Please make sure your disk contains both the screen and printer fonts that are used. Along with your disk, send a hard copy of all files that the Graphics Department will be producing and a list of the contents of the disk, marking the files that will be used.

What Resolution Do My Bitmap Files Need To Be?

The Graphics Department recommends printing all Lambda graphics using images that have a minimum input resolution of 100 ppi and a maximum of 200 ppi at final size. But keep in mind that even low resolution files will benefit from the high quality of Lambda output.

How Should I Save My File?

Please DO NOT save your Quark files as an EPS. Most of these files are locked, meaning that the Graphics Department cannot manipulate the content, proportion or color of the file in any way. If you are placing a Quark EPS in another file, please include all support files. Save any PhotoShop files as a PSD file in layers if you can.



What Colors Can I Use In My Layout?

The Graphics Department accepts RGB and CMYK files. Please indicate any color matches by specifying a PMS color that you would like to have matched.

What Are Some Things For Me To Consider Before Sending My Files?

- Neither the Digital Inkjet nor Lambda processes can replicate colors such as fluorescents, neons, and metallics
- Traditional can replicate metallics, fluorescents and neons.
- It is important to list critical PMS color matches for Inkjet prints in your files and on hard copies
- Logos and type should be created in the same program since PMS colors can be different from one program to another (For example: Illustrators PMS 321 may not be the same as Quarks PMS 321)
- Use one of the generic color spaces RGB, color match RGB.ICC, or PhotoShop 5 CMYK default when working in PhotoShop
- If you are requesting a specific element to be color matched in a bitmap file, please send the layered Photoshop file along with that element on it's own layer

Single or Multiple Pages

- Q.** My layout is for multiple mural panels, should I set my artwork up in separate pages?
- A.** No, you should not set up any continuous images, ie. Multiple mural panel systems, in separate pages or files.

In an effort to insure the best possible line-up of continuous images, the Graphics Department requests that all art be set up in one file. Precision tiling of your image will take place in our production process. The Graphics Department requests that you supply your images at the exact width. Of course, it is always a good idea to include the guides on all layouts to better communicate your expectations. In order to insure accurate line-up of all your mural graphics, a charge may be incurred to rebuild separate files into a single layout.

Can I Use Transparencies And Shadow Features In Illustrator?

Illustrator has some features that work unpredictably with the Graphics Department's large format rip systems. Although some of these features are great for web design, they increase the probability that what is produced, is not what the designer intended. Shadows are a problem and the Graphics Department recommends these be achieved through PhotoShop. PhotoShop has some great new features which work wonderfully. Not only do some of

these features in Illustrator increase turnaround time, but images are produced with unexpected results. Illustrator also includes new color management features that do not work. Adobe is aware of all the frustrations that are being experienced. The Graphics Department recommends you do not use these features in Illustrator. Sending files created in Illustrator that do not contain either mentioned feature, is acceptable.

LOADING GRAPHICS TO FTP SITE

The graphic files used for the artwork are typically very large regardless of the program you use. An easy and acceptable alternative to providing a CD is to use our FTP site for file upload.

OPTIMA GRAPHICS FTP PROCEDURES

Contact your Classic Project Manager before uploading any graphic files to Optima. The Project Manager will provide you with a unique job number and file name.

If using a web browser go to www.aproofnow.com
username: artwork password: trdshw

You can only attach one file at a time or a compressed file to this address, not a folder.

If using an ftp software program go to [ftp.aproofnow.com](ftp://ftp.aproofnow.com)
username: ftpuser password: ftp0401

The folder will be blank because you will not be able to see anything on this site. Drag and drop a compressed file and label it: TradeshowDistributor_JobName
Example: ClassicExhibits_UnitedCoatings

If you have any questions, please contact the Optima Graphics Department at 800.844.8877.